



Wolverine

SKID STEER ATTACHMENT

PRODUCT MANUAL

V2024.10.22

60IN DRUM MULCHER MANUAL

Model: DUM-26-73W



**FOR MORE INFO
SCAN HERE**



Content

I. Preface	1
II. Security Statements	2
III. Warning Labels	3
Warning Label Location	3
IV. Technical Parameters	5
V. Installation	6
Components	6
Detailed List	7
VI. Operation Precautions	9
On the Farm	9
Residential Landscaping	9
VII. Features	10

I. Preface

Congratulations on purchasing our new product! This product is designed for durability and years of reliable service with minimal maintenance, such as cleaning and lubrication, to keep it in top condition. Be sure to follow all maintenance procedures and safety precautions outlined in this manual, as well as any safety decals on the product and installation attachments.

This manual is intended to help you work more safely and efficiently. Please read it thoroughly and ensure anyone operating the equipment does the same.

The illustrations and data in this manual are up-to-date at the time of printing, but we reserve the right to redesign or modify attachments as needed without notice. The safe operation of this equipment is the operator's responsibility. Only trained personnel who have read and understood this manual should operate the equipment. If you have any questions, contact your local dealer or manufacturer for assistance. Keep this manual for reference and provide it to new owners or operators.

II. Security statements

Improper installation, operation, or maintenance of this equipment can result in serious injury or death. Before starting, operators and maintenance personnel must read this manual and all related manuals thoroughly. Follow all safety instructions.

Read and understand all safety warnings. Familiarize yourself with regulations, local laws, and guidelines. Always follow best practices when assembling, maintaining, repairing, installing, or operating the equipment.

Know your equipment's performance, size, and operation. Inspect before use, do not operate if safety devices are compromised. Tighten hardware, secure locks and connections, and replace any damaged or worn parts. Ensure safety labels are clear and replace if necessary.

III. Warning labels

Warning Label Location

The location of the warning labels used is shown in **Figure1-1**. Warning labels are identified by their part number and instructions for using the warning labels are shown in 1-2. Use this information to order replacements for lost or damaged warning labels. Be sure to read all warning label before handling accessories. They contain the information you need to understand and the safety and life span of the product.

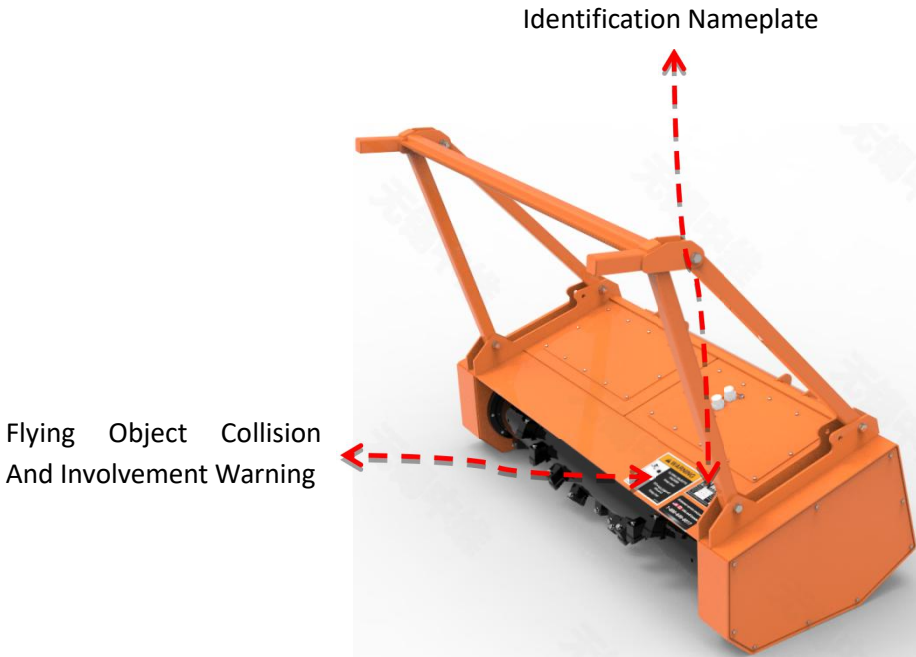
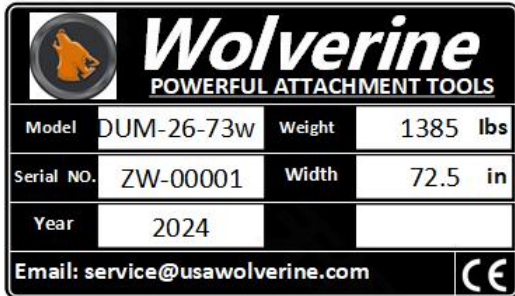

Figure 1-1



Warning Label
Flying Objects Hazard and
Entanglement Hazard



Name Plate

IV. Technical Parameters

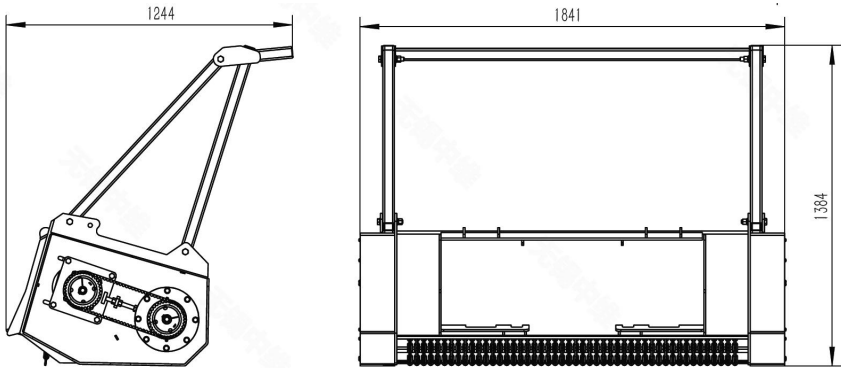

No.	Content	Parameter	
	Model	DUM-26-73W	
		Imperial Parameters	Metric Parameters
1	Total Equipment Weight	1400 lbs	635 Kg
2	Overall Width	72.5 "	1841 Mm
3	Equipment Height	54.5 "	1384 Mm
4	Equipment Length	49 "	1244 Mm
5	Spindle Working Width	60 "	1524 Mm
6	Adapter Loader	Skid Steer Loader	
7	Pioneer Tooth	Horseshoe-shaped pioneer teeth with tungsten steel or alloy steel tips	
8	Transmission Mode	Synchronous Belt	

V. Installation

Components

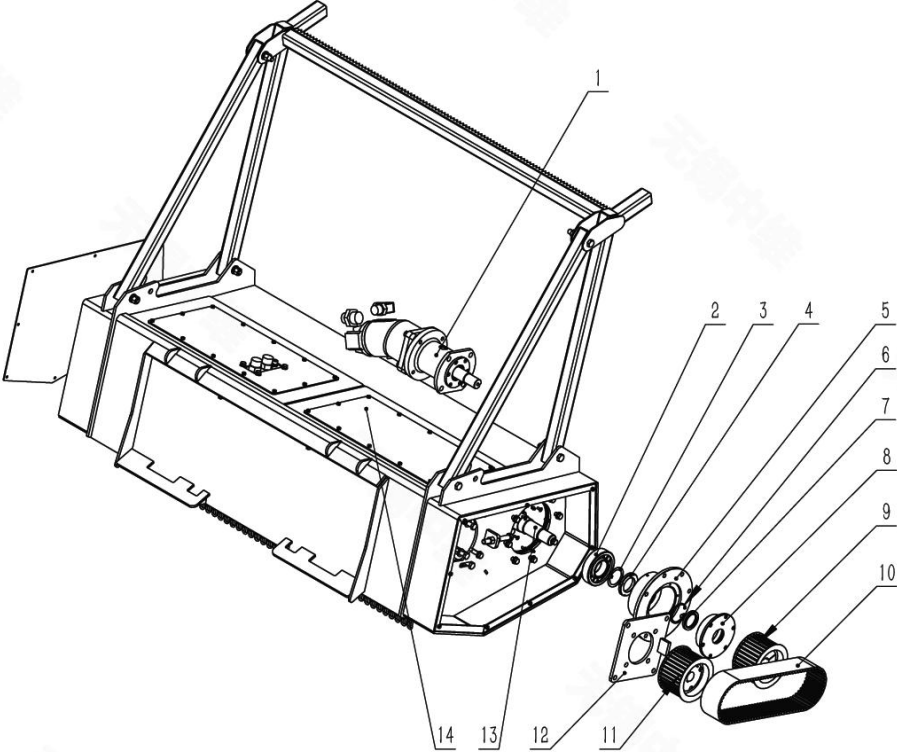

Detailed List

60 Drum Mulcher Detailed List					
No.	Code	Name	Material	Spec.	Qty.
1		Quantitative Pump (Motor)		A2F55R2P4	1
2	GB/T 283-2007	Cylindrical Roller Bearing	Steel	NUP 312 E / NU 312E	2
3	GB/T 858-1988	Locking Washer for Round Nut	Steel	56	2
4	GB/T 812-1988	Round Nut	Steel	M56*2	2
5	ZW-GTHJ-12	Bearing Seat - Left & Right	45 Steel		2
6	GB/T 893-2017	Elastic Retaining Ring for Holes	Steel	Type A 70	2
7	GB/T 13871.1-2007	Skeleton Oil Seal	Steel	With Secondary Lip Assembly (FZ Type) 50x70x8	2
8	ZW-GTHJ-08	Outer End Cover for Bearing	45 Steel		2
9		Driven Wheel Assembly			1

WOLVERINE INDUSTRY

10		Synchronous Belt	NR (Natural Rubber)		1
11		Drive Wheel Assembly	Q235B		1
12	ZW-GTHJ-09	Transmission Box Fixing Assembly	Welded Drawing		1
13	ZW-GTHJ-02-01	Spindle Assembly	Welded Drawing		1
14	ZW-GTHJ-07	Motor Side Cover Plate	Q235		1

VI. Operation Precautions

This Drum mulchers are built for high-performance cutting and mulching of vegetation and undergrowth in wooded areas. The hydraulic system reduces saplings, shrubs, and trees into mulch, making it perfect for environmental upkeep, like creating firebreaks. Other uses include reclaiming unused land, clearing vegetation from construction sites, and shredding pruned material and organic waste for biomass production.

On the Farm

1. Clearing crop perimeters allows for additional sunlight exposure and results in more productive crop growth.
2. Clear fence rows to keep machinery from being damaged during planting, maintenance or harvest.
3. Complete vegetation removal down to ground level to avoid potential livestock injuries.

Residential Landscaping

1. general vegetation management
2. fire prevention-create defensible space

VII. Features

- Axial piston motor provides smooth, efficient performance while delivering optimal torque under changing material loads.
- Rugged mulching head processes trees up to 200 mm (8 in) in diameter for effective land clearing applications.
- Fixed tooth balanced rotor provides excellent operating efficiency at high speeds. Single bolt retention allows for quick tooth replacement.
- Rear chain guard protection reduces the spread of material. Rugged, opposing edge design holds the work tool securely and allows the operator to quickly change from one high performance work tool to another.
- Compact body design ensure carrier is agile in the woods.



Multiple Tooth Options

Match any land management application



Rear Chain Protection

WARNING: Hydraulic oil/diesel fuel spilled under pressure can penetrate the skin and cause serious injury. Fluid spilling from a very small hole is almost invisible. Use a piece of cardboard or wood, not your hands, to look for suspicious leaks.



Wolverine

Tel: 1-800-649-8017

Business: sales@usawolverine.com

AS service: service@usawolverine.com

Website: www.usawolverine.com

WOLVERINE ATTACHMENT